



## SERIES MS2 | MAGNESENSE® II DIFFERENTIAL PRESSURE TRANSMITTER



### FEATURES/BENEFITS

- Field selectable ranges and output signal reduce inventory and the chances of ordering an incorrect part
- BACnet or Modbus serial communications reduce wiring cost by daisy-chaining the transmitters
- Our integral field-upgradeable display or plug-in remote display tool save upfront material cost and allow for local viewing of measurements

### APPLICATIONS

- Filter monitoring in air handler units
- Building pressure in pharmaceutical-semiconductor clean rooms
- Duct static pressure in commercial buildings
- Air velocity/flow in VAV systems

### DESCRIPTION

The **Series MS2 Magnesense® II Differential Pressure Transmitter** combines stable piezo sensing technology with additional features to reduce installation time and simplify ordering. Like the original Series MS, the second generation transmitter can be used as a linear pressure output or a linear velocity output with the square root extraction done in the transmitter. Additional parameters have been included on the MS2 to expand the square root capability to include flow measurements.

### SPECIFICATIONS

<b>Supported Baud Rates</b>	9600, 19200, 38400, 57600, 76800, 115200.
<b>Data Size</b>	8.
<b>Parity</b>	None.
<b>Stop Bits</b>	1.
<b>Service</b>	Air and non-combustible, compatible gases.
<b>Wetted Materials</b>	Consult factory.
<b>Typical Accuracy</b>	±1% FS for 0.15 in w.c. (40 Pa), 0.25 in w.c. (50 Pa), 0.5 in w.c. (100 Pa), 2 in w.c. (500 Pa), 3 in w.c. (750 Pa), 5 in w.c. (1250 Pa), 10 in w.c. (2 kPa), 15 in w.c. (3 kPa), 25 in w.c. (5 kPa), 28 in w.c. (6.975 kPa); ±2% FS for 0.1 in w.c. (25 Pa), 1 in w.c. (250 Pa), and all bi-directional ranges.
<b>Stability</b>	±1% / year FSO.
<b>Temperature Limits</b>	0 to 150°F (-18 to 66°C).
<b>Pressure Limits</b>	1 psi max., operation; 10 psi burst.
<b>Power Requirements</b>	10-35 VDC (2-wire), 17-36 VDC or isolated 21.6-33 VAC (3-wire).
<b>Output Signals</b>	4-20 mA (2-wire), 0-5 VDC, 0-10 VDC (3-wire).
<b>Response Time</b>	Averaging 0 to 240 s, 2.5 Hz sample rate, 1.5 to 228 s for 95% step change.
<b>Zero &amp; Span Adjustments</b>	Digital push buttons.
<b>Loop Resistance</b>	Current output: 0 to 1250 Ω max; Voltage output: Min. load resistance 1 kΩ.
<b>Current Consumption</b>	40 mA max.
<b>Display (Optional)</b>	5 digit LCD.
<b>Electrical Connections</b>	3-wire removable European style terminal block for 16 to 22 AWG.
<b>Electrical Entry</b>	1/2" NPS thread; Accessory (A-151): Cable gland for 5 to 10 mm diameter cable.
<b>Process Connection</b>	3/16" ID tubing (5 mm ID); Max. OD 9 mm.
<b>Enclosure Rating</b>	NEMA 4X (IP66).
<b>Mounting Orientation</b>	Any orientation.
<b>Weight</b>	8.0 oz (230 g).
<b>Agency Approvals</b>	BTL, CE.

## DIMENSIONS

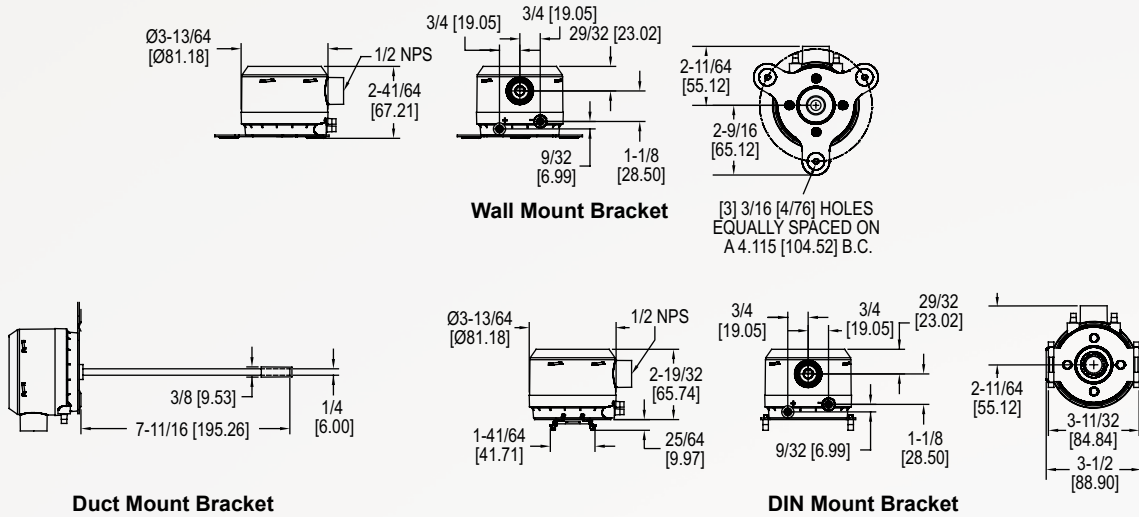

## HOW TO ORDER

Use the **bold** characters from the chart below to construct a product code.

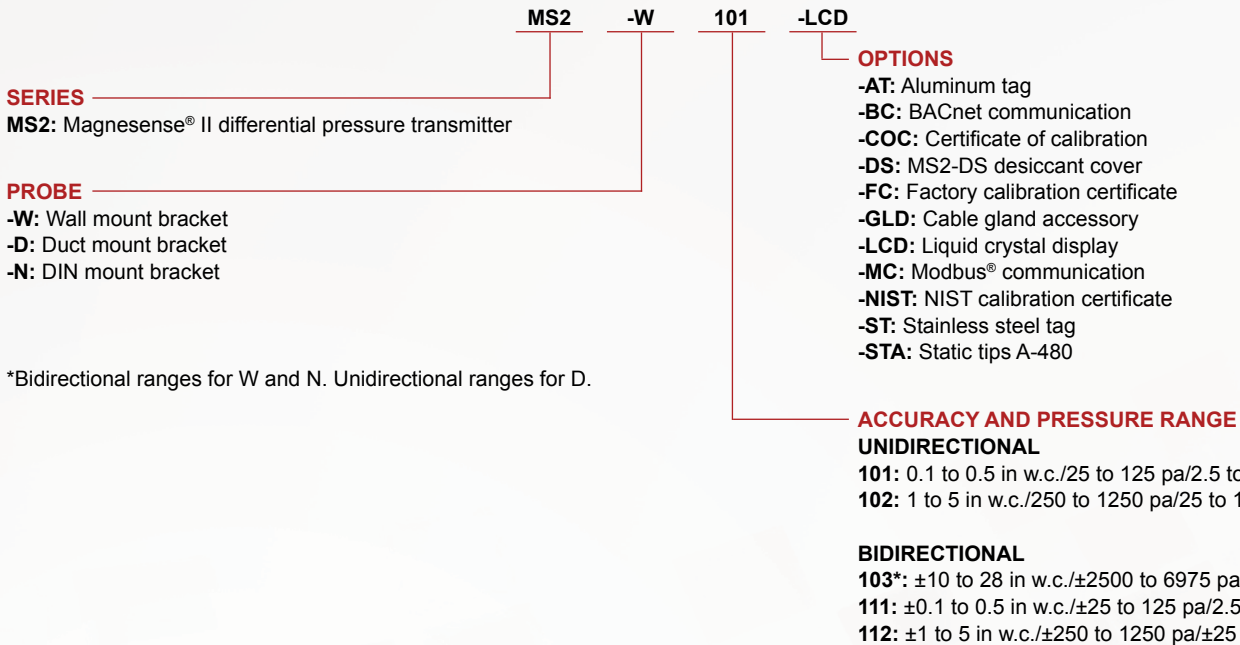

\*Bidirectional ranges for W and N. Unidirectional ranges for D.

## ACCESSORIES

Model	Description
<b>A-151</b>	Cable gland for 5 to 10 mm diameter cable
<b>A-MS2-LCD</b>	Field upgradeable display
<b>A-435-A</b>	Remote display tool
<b>A-480</b>	Plastic static pressure tip
<b>A-481</b>	Installer kit; includes 2 plastic static pressure tips and 7 ft (2.1 m) of PVC tubing
<b>A-489</b>	4" 303 SS straight static pressure tip with flange
<b>A-302F-A</b>	4" 303 SS static pressure tip with mounting flange; for 3/16" ID rubber or plastic tubing
<b>SCD-PS</b>	100-240 VAC/VDC to 24 VDC power supply

## ORDER ONLINE TODAY!

[dwyer-inst.com/Product/SeriesMS2](http://dwyer-inst.com/Product/SeriesMS2)

Modbus® is a registered trademark of Schneider Automation, Inc.



**DWYER INSTRUMENTS, INC.**

©Copyright 2020 Dwyer Instruments, Inc.  
Printed in U.S.A. 6/20

DS-MS2 Rev. 6

Important Notice: Dwyer Instruments, Inc. reserves the right to make changes to or discontinue any product or service identified in this publication without notice. Dwyer advises its customers to obtain the latest version of the relevant information to verify, before placing any orders, that the information being relied upon is current.